

Introduction to Clinical Supervision

- An introductory course that will equip attendees with basic skills and knowledge to provide clinical supervision within the workplace
- Clinicians working in primary and community care environment from the wider workforce professions
- GPs who wish to explore how to support their staff better without committing to becoming a GP Trainer



Introduction to Clinical Supervision

The aims of the course are:

- ✓ To explore clinical supervision, its role and its function
- ✓ To explore some different models of clinical supervision and their application in practice
- ✓ To understand how reflective questions can support clinical supervision
- ✓ To understand accountabilities and responsibilities of the clinical supervisor and supervisee
- ✓ Tips for implementing clinical supervision in the workplace



Introduction to becoming an educational supervisor

- An introductory course that will equip attendees with some educational theory, an understanding of educator knowledge and skills requirements and an introduction work-based assessment (WBAs)
- Clinicians working in primary and community care environment from the wider workforce professions
- GPs who wish to explore how to support their staff better without committing to becoming a GP Trainer
- Recommended - Introduction to Clinical Supervision or equivalent course and/or experience as a clinical supervisor



Introduction to becoming an educational supervisor

The aims of the course are:

- ✓ To appreciate the different forms supervision can take
- ✓ To understand different adult learning theories
- ✓ To understand the roles and responsibilities of an educational supervisor
- ✓ To have a high-level appreciation of different Work Based Assessments



Education supervisor pathway

- A multi-professional course which provides the background knowledge and skills required to be an effective educational supervisor e.g.
- First Contact Practitioners/ACP/GP trainees/NMP/pre and post grad nurses and AHPs.
- Clinicians working in primary and community care environment from the wider workforce professions. Reduce the burden on senior nurses.
- GPs who wish to become GP Trainers / Associates
- Recommended - Introduction to Educational supervision

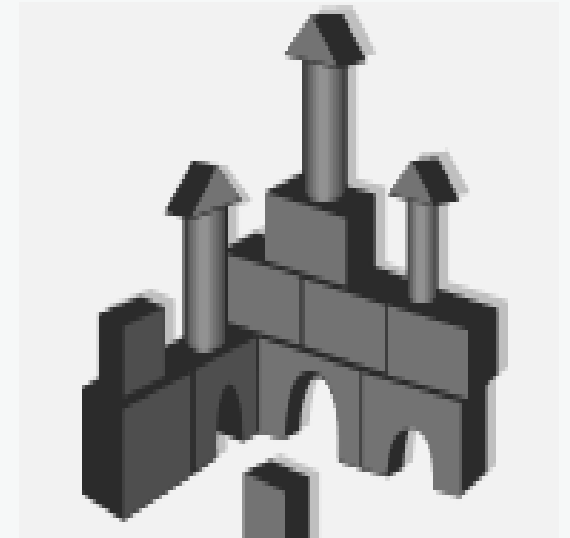

Education supervisor pathway

The aims of the pathway are:

- ✓ To know how to ensure safe and affective patient care through training
- ✓ To establish and maintain an environment for learning
- ✓ To be able to teach and facilitate learning
- ✓ To appreciate how to enhance learning via assessment
- ✓ To support and monitor educational progress
- ✓ To be able to guide personal and professional development
- ✓ To support CPD as an educator

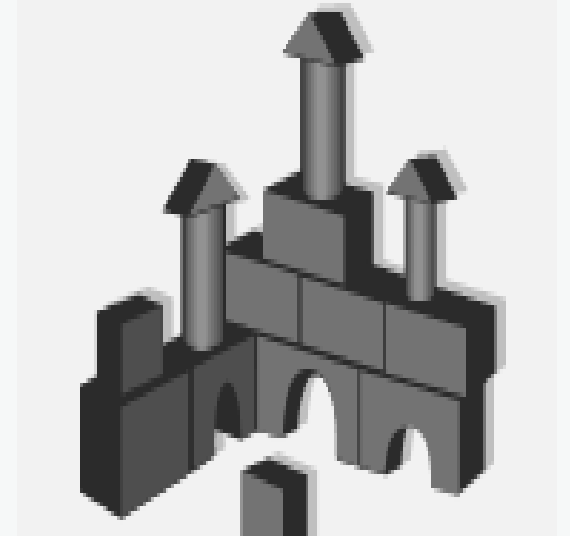

Community of Practice – Maintaining Educator knowledge, skills and behaviours

- Support and provide access to educator learning and development
- maintain, and refresh educator capabilities through ongoing CPD activities
- Promote the role of educator within individual learning areas/environments
- Include ongoing development as an educator in appraisal action plan/objectives



To summarise supervisors should:-

- Promote and ensure safe and effective patient care through robust work-based education,
- To establish and maintain an environment for learning
- To be able to teach and facilitate learning
- To appreciate how to enhance learning via work-based assessment and have the skills to do this successfully
- To support and monitor educational progress
- To be able to guide personal and professional development
- To have access to Continual Professional Development as an educator



England



@nhsengland



company/nhsengland



england.nhs.uk